

FRANKE TRIFLOW

Valve Change Guide - Trend V1

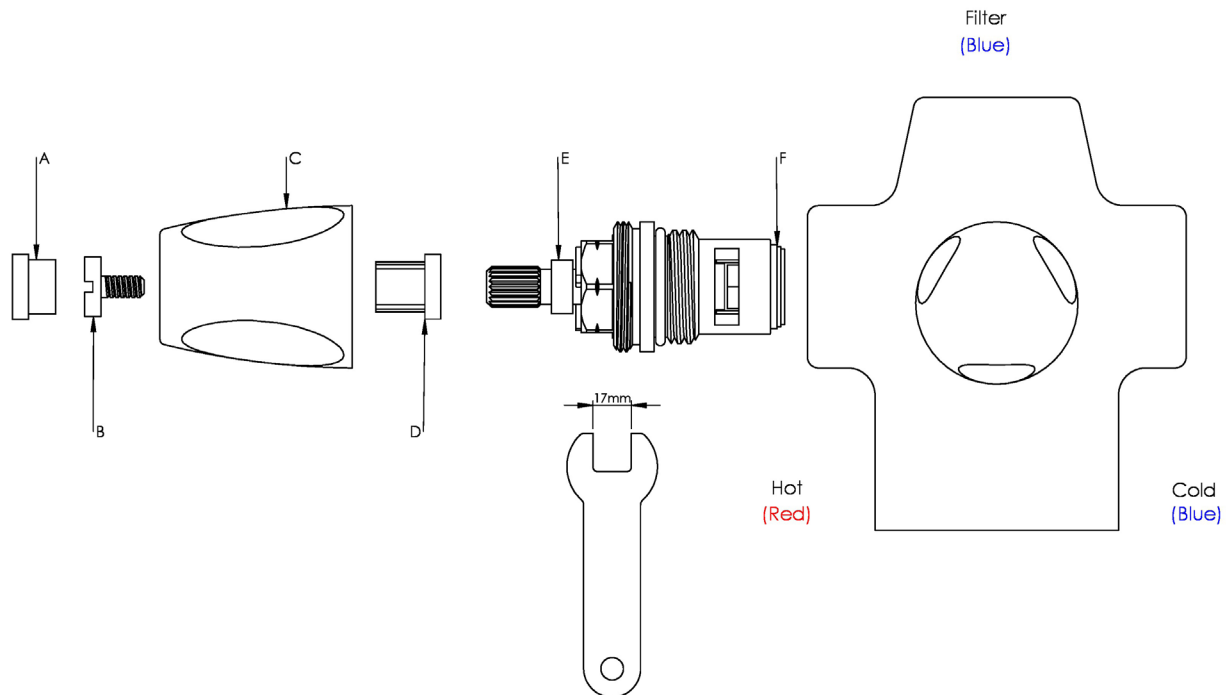

Before you begin

Replacing the valves of a Trend tap is a straightforward procedure for any competent handyperson. However, should you have any doubts about your ability to tackle the task we suggest you engage a suitably qualified professional.

The tools you will need

1. 17mm ring spanner or a medium size adjustable spanner.

The valve change procedure

1. Turn off the water supply to the tap.
2. Remove the coloured index (A) from the centre of the handle by inserting a small flat bladed screwdriver at the edge and carefully prising it out.
3. Unscrew and remove the handle retaining screw (B).
4. Remove the handle (C)
5. Unscrew the old valve (E) using a 17 mm spanner or a suitable adjustable one. Bear in mind that it might take some initial force to free the valve if it has been in place for some time.
6. Select the correct valve, as they are handed. The valves are identifiable by the colour of the silicon insert (F) - you should have one red one and two blue. Viewing the tap from the front (refer to the diagram above). The red valve should be installed on the left (hot) side. A blue valve should be installed on the right (cold) side. A blue valve should be installed in the centre (filtered water) position.
7. Screw each valve in its correct location, as described above, and tighten firmly.
8. Refit the handle retaining screw, tighten it firmly, and push the coloured index back in place.
9. Turn the water supply back on and check for leaks.

FRANKE

GRL Direct
+44 (0)1603 875468
contact@grldirect.co.uk
www.grldirect.co.uk