

FRANKE TRIFLOW

Valve Change Guide - Trend V2

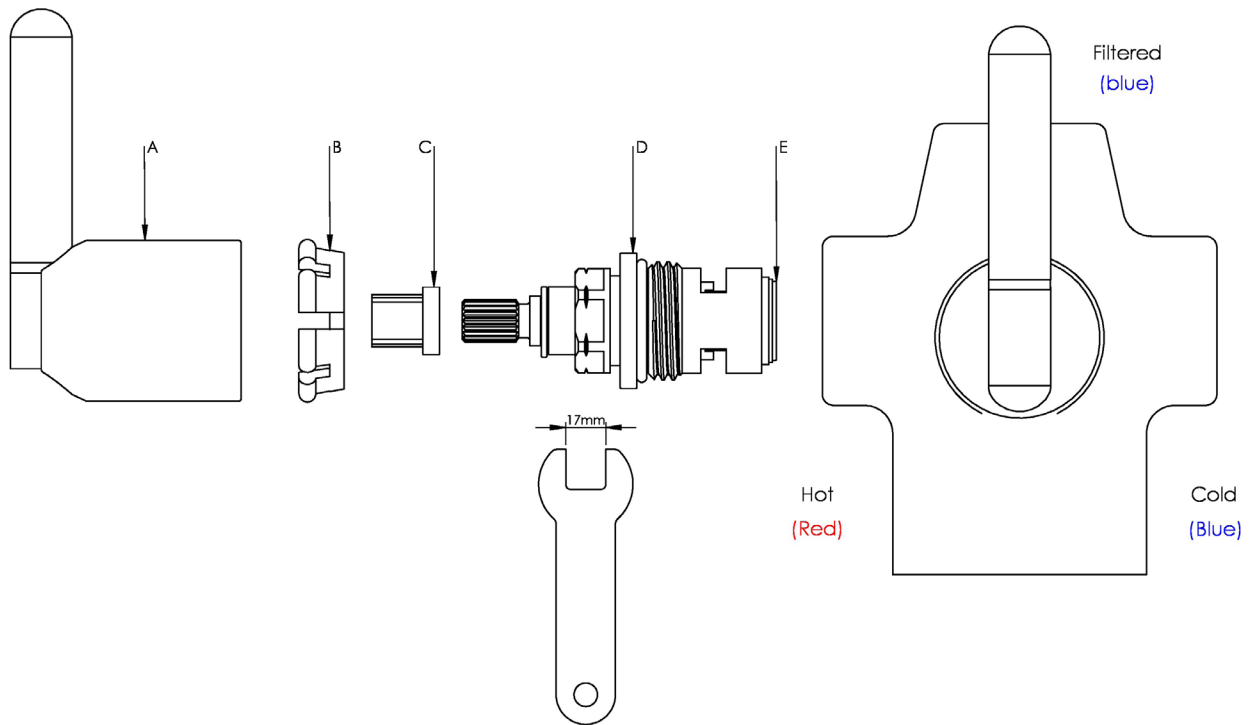

Before you begin

Replacing the valves of a Trend tap is a straightforward procedure for any competent handyperson. However, should you have any doubts about your ability to tackle the task we suggest you engage a suitably qualified professional.

The tools you will need

1. 17mm ring spanner or a suitable adjustable spanner.

The valve change procedure

1. Turn off the water supply to the tap.
2. Pull off the lever handle assembly (A). A firm pull will be required. Caution — using a screwdriver to lever off the handle may result in damage to the plated finish of the tap.
3. Remove the plastic Vernier Insert (C). It will either remain on the end of the old valve or stay inside the handle (a new vernier insert is supplied with each new valve).
4. Unscrew the old valve (D) using a 17 mm spanner or a suitable adjustable one. Bear in mind that it might take some initial force to free the valve if it has been in place for some time.
5. The valves are handed so take care to select the correct one. The valves are identifiable by the colour of the silicon insert (E) - you should have one red one and two blue. Referring to the above diagram — viewed from the front the red valve should be installed on the left (hot) side and a blue valve should be installed on the right (cold) side. A blue valve should be installed in the centre (filtered water) position.
6. Screw each valve in its correct location as described above, and tighten firmly.
7. Check the spindle of each valve is in the closed position then slide the new vernier insert on the splined valve spindle. Align the handle as close to vertical as you can manage, but without clipping in on fully. If the handle is not vertical, remove it carefully while keeping the vernier insert in place. Slide off the vernier insert and rotate it one or two notches. Try the handle again. Repeat this operation until you are satisfied with the lever alignment, then push the handle assembly fully home to engage the clip (B).
8. Turn the water supply back on and check for leaks.

FRANKE

GRL Direct
+44 (0)1603 875468
contact@grldirect.co.uk
www.grldirect.co.uk